

B
ブラシ

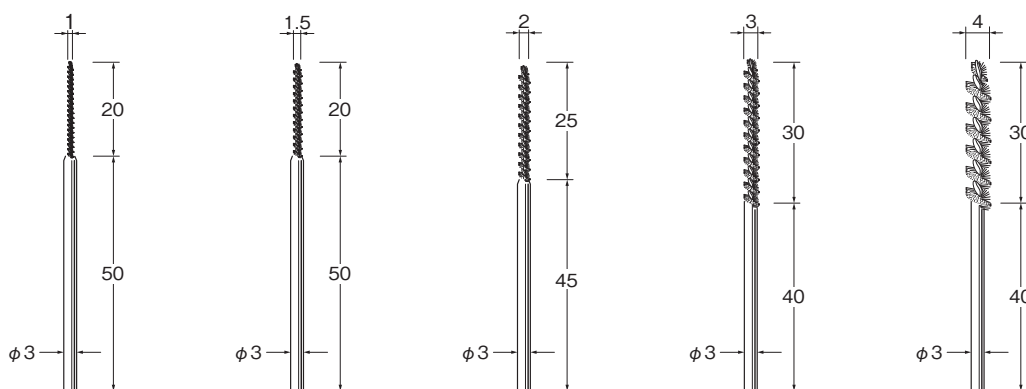

ステンレス線	B8500 線径 φ0.06	B8510 線径 φ0.06	B8520 線径 φ0.06	B8530 線径 φ0.08	B8540 線径 φ0.08
--------	-------------------	-------------------	-------------------	-------------------	-------------------

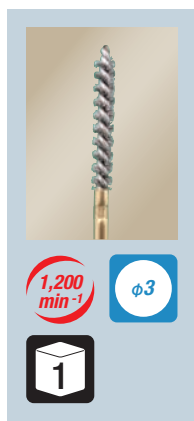
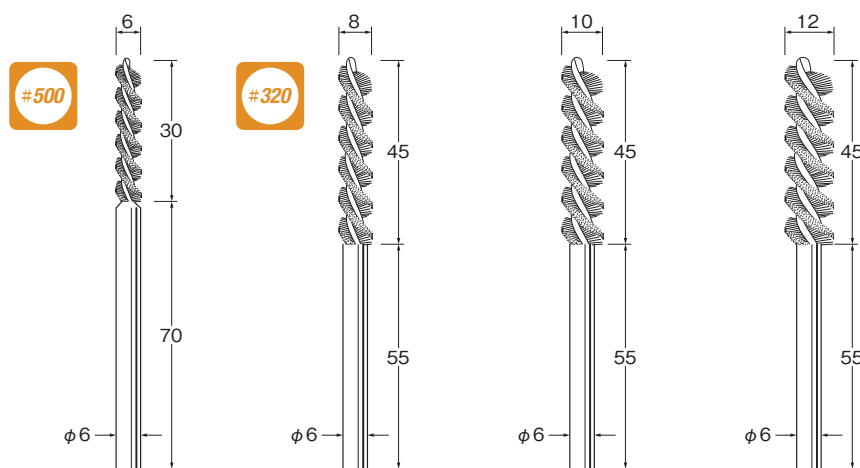
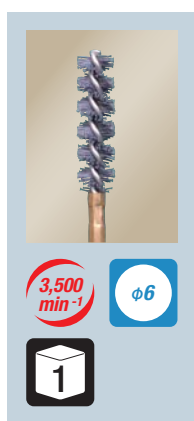

研磨材入りナイロン	B8606 線径 φ0.3	B8608 線径 φ0.55	B8610 線径 φ0.55	B8612 線径 φ0.55
-----------	------------------	-------------------	-------------------	-------------------

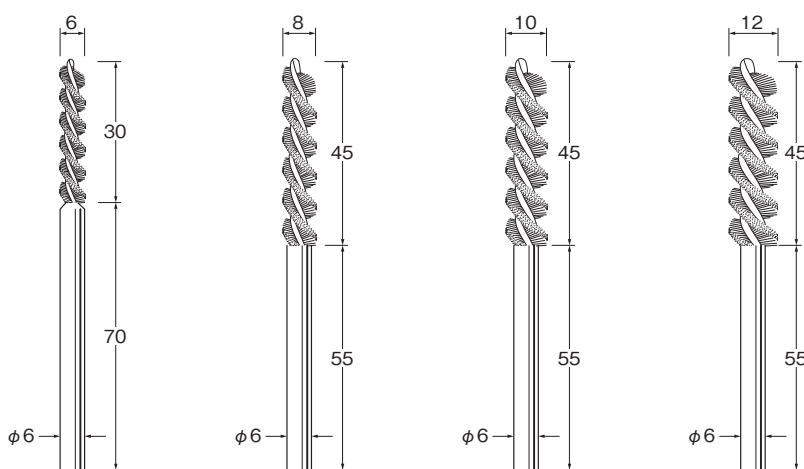

ステンレス線	B8706 線径 φ0.08	B8708 線径 φ0.1	B8710 線径 φ0.15	B8712 線径 φ0.15
--------	-------------------	------------------	-------------------	-------------------